

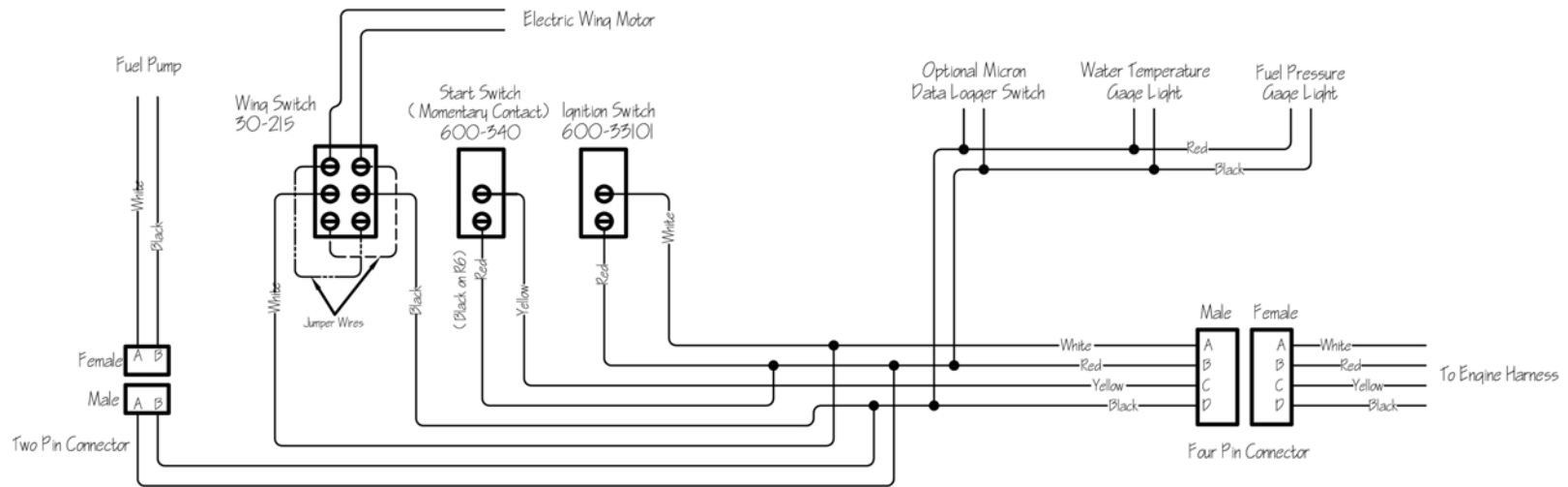

Chassis Harness Wiring Diagram



- Ground main engine harness to engine block with negative battery cable
- The only difference with the Yamaha chassis harness is the red wire on the push start button switch will be black

Chassis Harness to Engine Harness Chart

2003 & 2004 Kawasaki	Suzuki	2005 Kawasaki	Yamaha R6	Honda F4i, RR, F2 & F3
White — White	White — Red	White — White	White — Red	White — Red
Red — Brown	Red — Orange/ White	Red — Brown	Red — Red/ White	Red — Black/ White
Yellow — Yellow/ Red	Yellow — Yellow/ Green	Yellow — Black/ Red	Yellow — Blue/ White	Yellow — Yellow/ Red
Black — Black to Ground	Black — Black to Ground	Black — Black to Ground	Black — Black to Ground	Black — Black to Ground

- 1-Clip or tie off yellow, white and blue wires.
- 2-Connect Red and black to switch using diagram above